

ID	A	B	C	D	E	F	G	WALL TYPE	D-LOAD CLASS	STEEL INNER/OUTER		WEIGHT
48"	8'-1 1/4"	7'-9"	5'-3 1/2"	4'-11 1/2"	7 3/4"	2"	5 3/4"	C	III	.16	.10	6,900 lbs
48"	8'-1 1/4"	7'-9"	5'-3 1/2"	4'-11 1/2"	7 3/4"	2"	5 3/4"	C	IV	.26	.16	6,900 lbs
48"	8'-1 1/4"	7'-9"	5'-3 1/2"	4'-11 1/2"	7 3/4"	2"	5 3/4"	C	V	.47	.27	6,900 lbs

* STEEL USED WILL MEET OR EXCEED ASTM C76

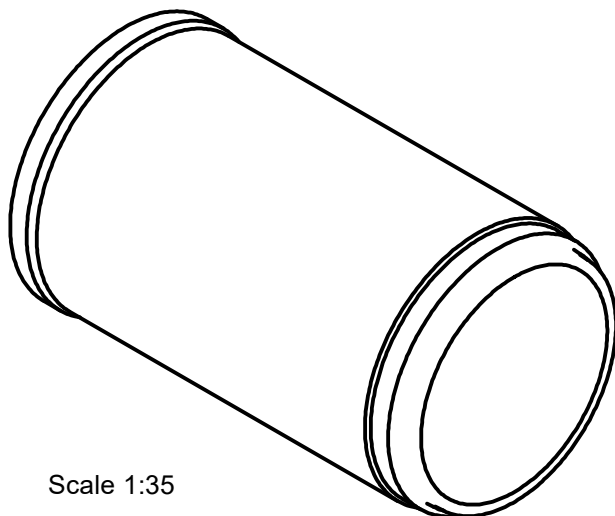

Scale 1:35

ISOMETRIC VIEW

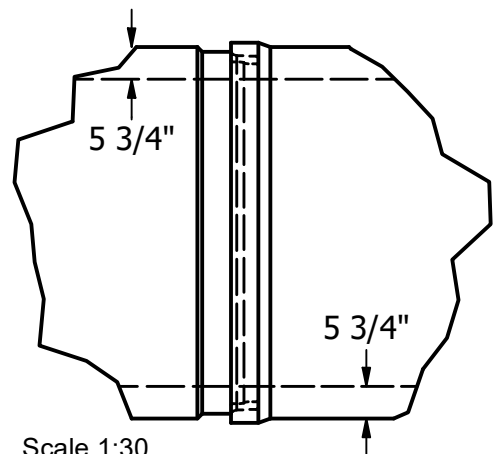

Scale 1:30

RUBBER GASKET JOINT DETAIL

Notes:

1. ALL DIMENSIONS SUBJECT TO ALLOWABLE SPECIFICATION TOLERANCES AND PARAMETERS.
2. STEEL WWM ASTM A-1064, REINFORCING TO MEET AND/OR EXCEED ASTM-C76.
3. PIPE IS MANUFACTURED PER ASTM C-76, AND CONFORMS TO 2018 CALTRANS STANDARD SPECIFICATION SECTION 65-2 REINFORCED CONCRETE PIPE.
4. INTERNAL RUBBER GASKET SHALL CONFORM TO AASHTO DESIGNATION M-198-75 AND ASTM C-443
5. CONCRETE F'c = 6000 PSI @ 28 DAYS



240 W. LOS ANGESE AVE. SIMI VALLEY, CA 93065
P: (805) 527-0841 F: (805) 584-0769,
WWW.PRE-CONPRODUCTS.COM

THE CONTENTS OF THESE DRAWINGS ARE THE PROPERTY OF PRECON PRODUCTS AND ARE PROPRIETARY AND CONFIDENTIAL. THESE DOCUMENTS SHALL NOT BE DISSEMINATED FOR ANY OTHER USE, WITHOUT THE WRITTEN CONSENT OF PRECON PRODUCTS. IF YOU RECEIVE THESE DRAWINGS IN ERROR, RETURN TO SENDER WITHOUT READING, COPYING OR DISCLOSING THE CONTENTS.

DRAWN BY:

W.Tack

DATE:

6/9/2021

TITLE:

48" x 8' RCP RG

SHEETS:

1 OF 2

DO NOT SCALE

BELL

5 3/4"

Ø48"

R1/2"

R1/4"

2°

2°

7/16"

2 1/4"

4 1/4"

R1/16"

1/8"

20°

2°

7/8"

R1/4"

SPIGOT

R3/8"

7 7/8"

Notes:

1. ALL DIMENSIONS SUBJECT TO ALLOWABLE SPECIFICATION TOLERANCES AND PARAMETERS.
2. STEEL WWM ASTM A-1064, REINFORCING TO MEET AND/OR EXCEED ASTM-C76.
3. PIPE IS MANUFACTURED PER ASTM C-76, AND CONFORMS TO 2018 CALTRANS STANDARD SPECIFICATION SECTION 65-2 REINFORCED CONCRETE PIPE.
4. INTERNAL RUBBER GASKET SHALL CONFORM TO AASHTO DESIGNATION M-198-75 AND ASTM C-443
5. CONCRETE F'c = 6000 PSI @ 28 DAYS



240 W. LOS ANGELES AVE. SIMI VALLEY, CA 93065
 P: (805) 527-0841 F: (805) 584-0769,
 WWW.PRE-CONPRODUCTS.COM

THE CONTENTS OF THESE DRAWINGS ARE THE PROPERTY OF PRECON PRODUCTS AND ARE PROPRIETARY AND CONFIDENTIAL. THESE DOCUMENTS SHALL NOT BE DISSEMINATED FOR ANY OTHER USE, WITHOUT THE WRITTEN CONSENT OF PRECON PRODUCTS. IF YOU RECEIVE THESE DRAWINGS IN ERROR, RETURN TO SENDER WITHOUT READING, COPYING OR DISCLOSING THE CONTENTS.

DRAWN BY:

W.Tack

DATE:

6/9/2021

TITLE:

48" RCP RG
 JOINT DETAIL

SHEETS:

2 OF 2

DO NOT SCALE