

ID	A	B	C	D	E	WALL TYPE	D-LOAD CLASS	STEEL INNER/OUTER	WEIGHT
36"	8'	7'-11"	3'-8"	3'-4 5/8"	4"	B	CL III	.17 .10	4,200 lbs
36"	8'	7'-11"	3'-8"	3'-4 5/8"	4"	B	CL IV	.30 .18	4,200 lbs
36"	8'	7'-11"	3'-8"	3'-4 5/8"	4"	B	CL V	.50 .30	4,200 lbs

* STEEL USED WILL MEET OR EXCEED ASTM C76

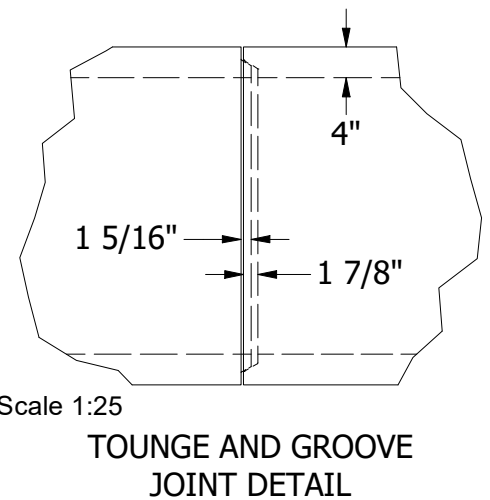
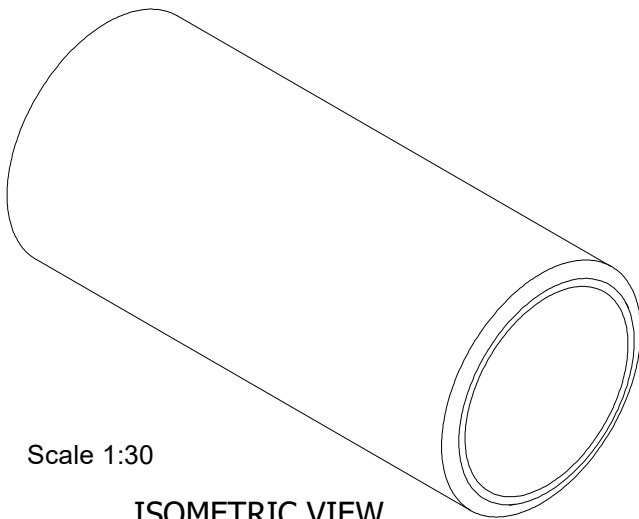

Notes:

1. ALL DIMENSIONS SUBJECT TO ALLOWABLE SPECIFICATION TOLERANCES AND PARAMETERS.
2. STEEL WWM ASTM A-497, REINFORCING PER ASTM-C76.
3. PIPE IS MANUFACTURED PER ASTM C-76, AND CONFORMS TO 2018 CALTRANS STANDARD SPECIFICATION SECTION 65-2 REINFORCED CONCRETE PIPE.
4. CONCRETE F'c = 6000 PSI @ 28 DAYS



240 W. LOS ANGELESE AVE. SIMI VALLEY, CA 93065
P: (805) 527-0841 F: (805) 584-0769,
WWW.PRE-CONPRODUCTS.COM

THE CONTENTS OF THESE DRAWINGS ARE THE PROPERTY OF PRECON PRODUCTS AND ARE PROPRIETARY AND CONFIDENTIAL. THESE DOCUMENTS SHALL NOT BE DISSEMINATED FOR ANY OTHER USE, WITHOUT THE WRITTEN CONSENT OF PRECON PRODUCTS. IF YOU RECEIVE THESE DRAWINGS IN ERROR, RETURN TO SENDER WITHOUT READING, COPYING OR DISCLOSING THE CONTENTS.

DRAWN BY:
W.Tack
DATE:
6/7/2021

TITLE:
36" x 8' RCP TG

SHEETS:
1 OF 1

DO NOT SCALE