

ID	A	B	C	D	G	WALL TYPE	D-LOAD CLASS	STEEL INNER/OUTER		WEIGHT
36"	8'-1"	7'-9"	4'-3 1/8"	3'-9 1/2"	4 3/4"	C	III	.08	.07	5,100 lbs
36"	8'-1"	7'-9"	4'-3 1/8"	3'-9 1/2"	4 3/4"	C	IV	.14	.08	5,100 lbs
36"	8'-1"	7'-9"	4'-3 1/8"	3'-9 1/2"	4 3/4"	C	V	.27	.16	5,100 lbs

* STEEL USED WILL MEET OR EXCEED ASTM C76

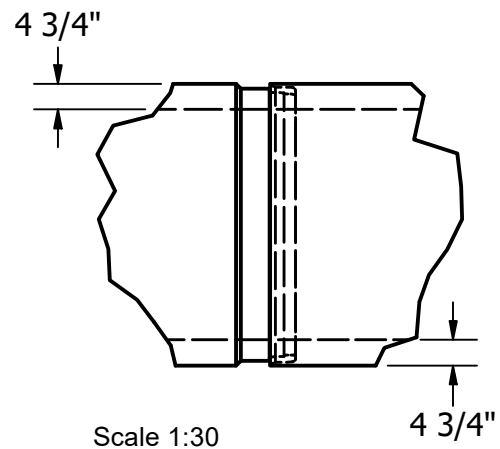
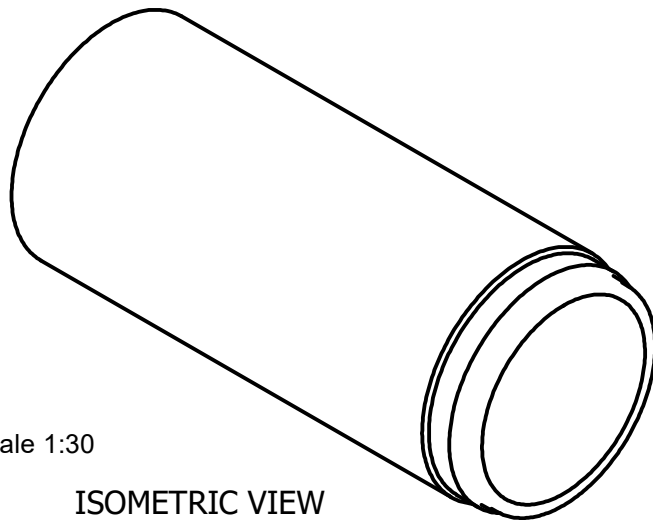

RUBBER GASKET
JOINT DETAIL

Notes:

1. ALL DIMENSIONS SUBJECT TO ALLOWABLE SPECIFICATION TOLERANCES AND PARAMETERS.
2. STEEL WWM ASTM A-1064, REINFORCING TO MEET AND/OR EXCEED ASTM-C76.
3. PIPE IS MANUFACTURED PER ASTM C-76, AND CONFORMS TO 2018 CALTRANS STANDARD SPECIFICATION SECTION 65-2 REINFORCED CONCRETE PIPE.
4. INTERNAL RUBBER GASKET SHALL CONFORM TO AASHTO DESIGNATION M-198-75 AND ASTM C-443
5. CONCRETE F_c = 6000 PSI @ 28 DAYS



240 W. LOS ANGELESE AVE. SIMI VALLEY, CA 93065
P: (805) 527-0841 F: (805) 584-0769,
WWW.PRE-CONPRODUCTS.COM

THE CONTENTS OF THESE DRAWINGS ARE THE PROPERTY OF PRECON PRODUCTS AND ARE PROPRIETARY AND CONFIDENTIAL. THESE DOCUMENTS SHALL NOT BE DISSEMINATED FOR ANY OTHER USE, WITHOUT THE WRITTEN CONSENT OF PRECON PRODUCTS. IF YOU RECEIVE THESE DRAWINGS IN ERROR, RETURN TO SENDER WITHOUT READING, COPYING OR DISCLOSING THE CONTENTS.

DRAWN BY:
W.Tack
DATE:
6/9/2021

TITLE:
36" x 8' RCP RG

SHEETS:
1 OF 2

DO NOT SCALE

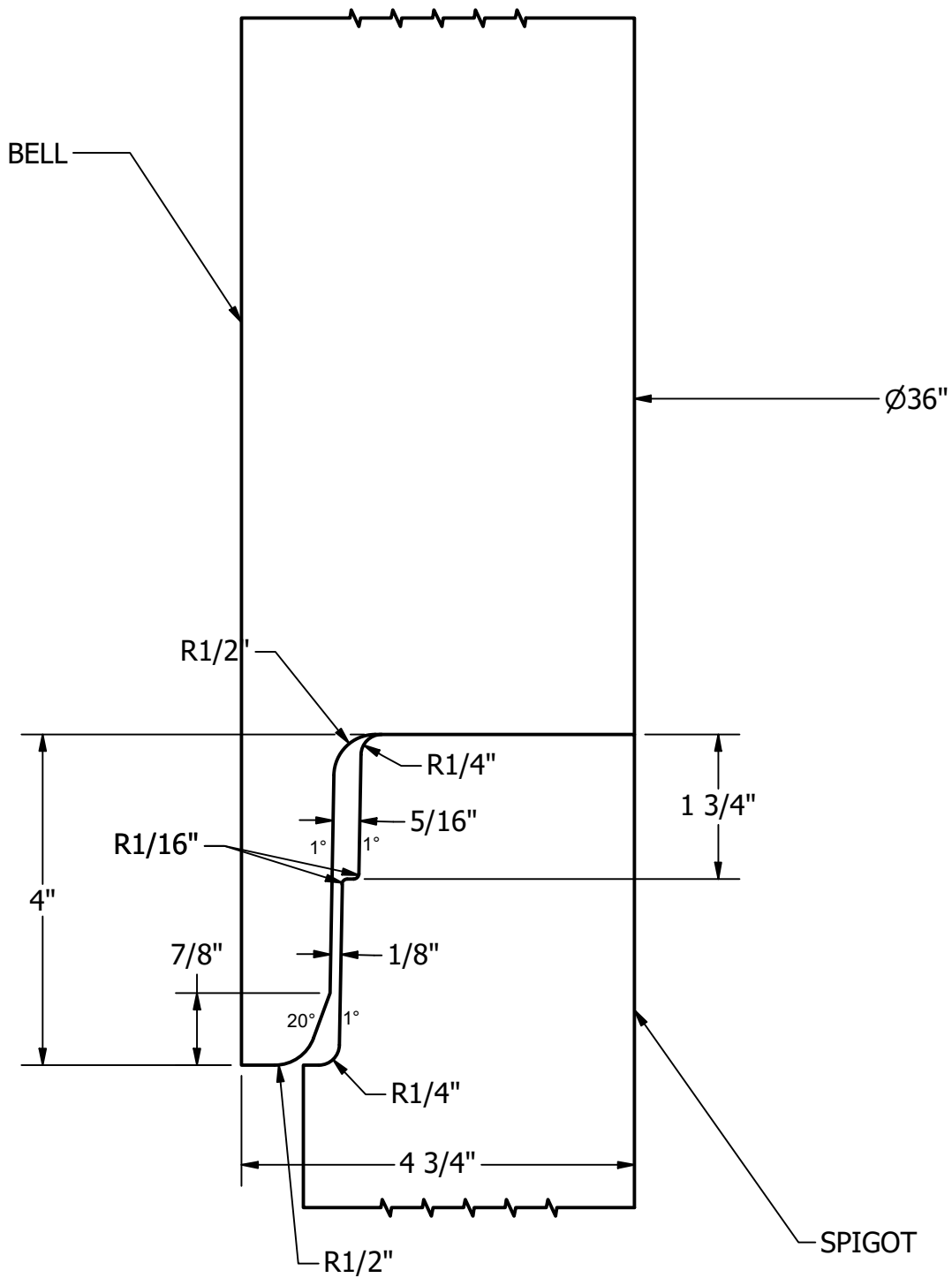

- Notes:
1. ALL DIMENSIONS SUBJECT TO ALLOWABLE SPECIFICATION TOLERANCES AND PARAMETERS.
 2. STEEL WWM ASTM A-1064, REINFORCING TO MEET AND/OR EXCEED ASTM-C76.
 3. PIPE IS MANUFACTURED PER ASTM C-76, AND CONFORMS TO 2018 CALTRANS STANDARD SPECIFICATION SECTION 65-2 REINFORCED CONCRETE PIPE.
 4. INTERNAL RUBBER GASKET SHALL CONFORM TO AASHTO DESIGNATION M-198-75 AND ASTM C-443
 5. CONCRETE F^c = 6000 PSI @ 28 DAYS



240 W. LOS ANGELESE AVE. SIMI VALLEY, CA 93065
 P: (805) 527-0841 F: (805) 584-0769,
 WWW.PRE-CONPRODUCTS.COM

THE CONTENTS OF THESE DRAWINGS ARE THE PROPERTY OF PRECON PRODUCTS AND ARE PROPRIETARY AND CONFIDENTIAL. THESE DOCUMENTS SHALL NOT BE DISSEMINATED FOR ANY OTHER USE, WITHOUT THE WRITTEN CONSENT OF PRECON PRODUCTS. IF YOU RECEIVE THESE DRAWINGS IN ERROR, RETURN TO SENDER WITHOUT READING, COPYING OR DISCLOSING THE CONTENTS.

DRAWN BY:
W.Tack
 DATE:
6/9/2021

TITLE:
**36" RCP RG
 JOINT DETAIL**

SHEETS:
2 OF 2
 DO NOT SCALE

LOCATION: T:\Drawings\Vault\DESIGN5\RCP\RG\36RCP\RGFL-8 SUBMITAL.dwg