

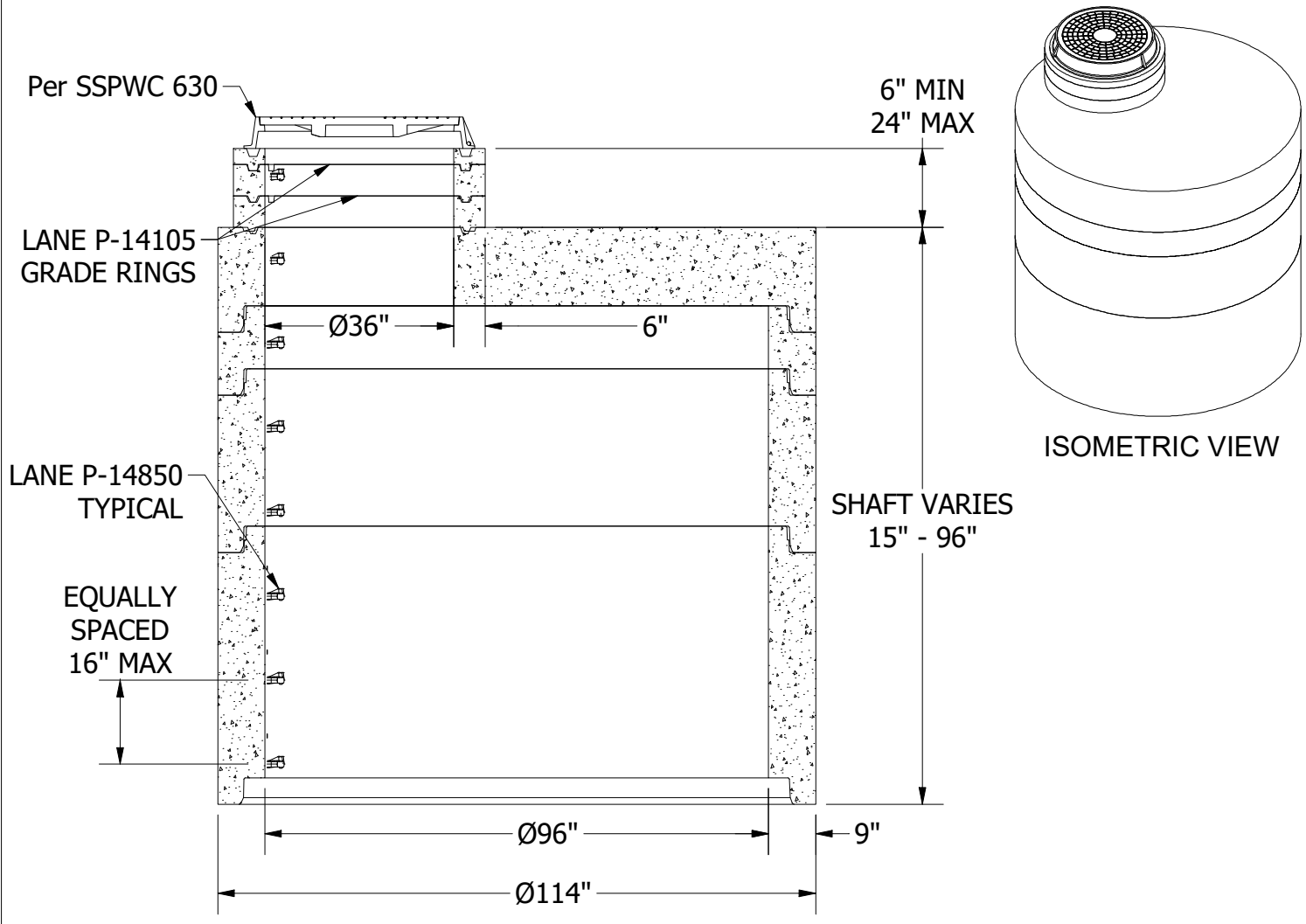

LOCATION: T:\Drawings\Vault\DESIGNS\MANHOLES\H CUT SHEETS\Standard\11H96\_SHAFT-STDw36x15-Step.dwg



**NOTES:** UNLESS OTHERWISE SPECIFIED.

1. ALL DIMENSIONS ARE IN DECIMAL INCHES.
2. PRECAST MATERIALS AND MANUFACTURING METHODS SHALL CONFORM TO ASTM C-478.
3. CONCRETE SHALL HAVE A MINIMUM COMPRESSIVE STRENGTH F C= 4000 PSI AT 28 DAYS.
4. THE PORTLAND CEMENT USED IN THE PRECAST SECTIONS SHALL MEET THE REQUIREMENTS OF TYPE II/V HIGH SULFATE RESISTANT CEMENT IN ACCORDANCE WITH ASTM C-150.
5. RING AND COVER SHALL BE GREY CAST IRON CONFORMING TO ASTM A-48 CLASS 35B.
6. RING AND COVER STYLE AND MARKINGS VARY BY SPECIFYING AGENCY.
7. PRE-CAST JOINTS SHALL BE SEALED USING MASTIC.
8. STEEL REINFORCED POLYETHYLENE STEPS SHALL CONFORM TO SPPWC AND APWA 636-1.

 <p>240 W. LOS ANGELESE AVE. SIMI VALLEY, CA 93065 P: (805) 527-0841 F: (805) 584-0769, WWW.PRE-CONPRODUCTS.COM</p>	<p>THE CONTENTS OF THESE DRAWINGS ARE THE PROPERTY OF PRECON PRODUCTS AND ARE PROPRIETARY AND CONFIDENTIAL. THESE DOCUMENTS SHALL NOT BE DISSEMINATED FOR ANY OTHER USE, WITHOUT THE WRITTEN CONSENT OF PRECON PRODUCTS. IF YOU RECEIVE THESE DRAWINGS IN ERROR, RETURN TO SENDER WITHOUT READING, COPYING OR DISCLOSING THE CONTENTS.</p>	<p>DRAWN BY: <b>W. TACK</b></p> <p>DATE: <b>7/7/2021</b></p>	<p>TITLE: <b>MANHOLE, 96" DIA, 36" RING AND COVER, WITH STEPS</b></p>	<p>SHEETS: <b>1 OF 1</b></p>
	<p>DO NOT SCALE</p>			