

Per SSPWC 630

LANE P-14105
GRADE RINGS

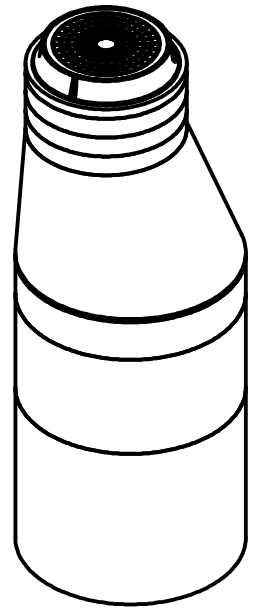
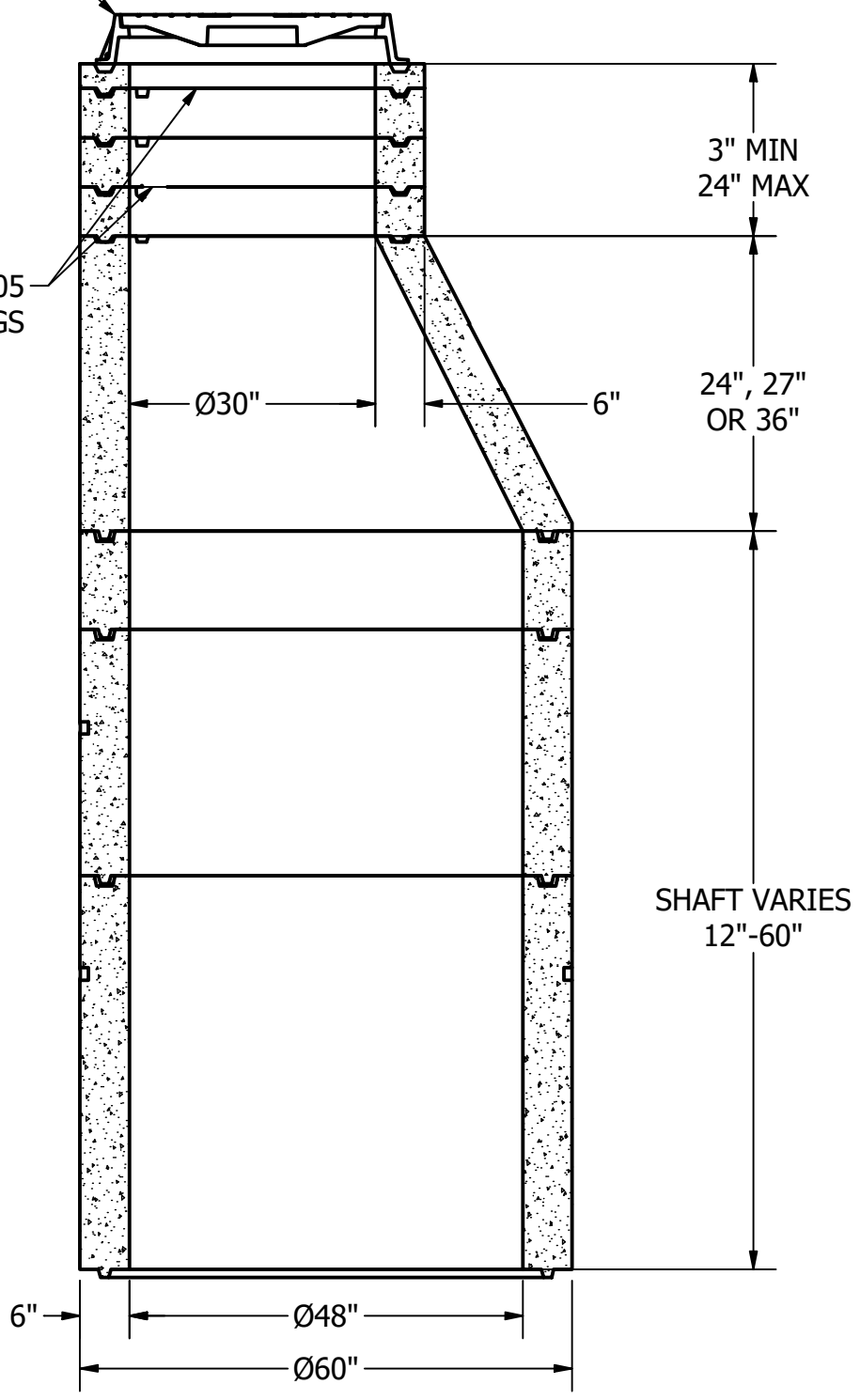

ISOMETRIC VIEW

SHAFT VARIES
12"-60"

NOTES: UNLESS OTHERWISE SPECIFIED.

1. ALL DIMENSIONS ARE IN DECIMAL INCHES.
2. PRECAST MATERIALS AND MANUFACTURING METHODS SHALL CONFORM TO ASTM C-478.
3. CONCRETE SHALL HAVE A MINIMUM COMPRESSIVE STRENGTH F C= 4000 PSI AT 28 DAYS.
4. THE PORTLAND CEMENT USED IN THE PRECAST SECTIONS SHALL MEET THE REQUIREMENTS OF TYPE II/V HIGH SULFATE RESISTANT CEMENT IN ACCORDANCE WITH ASTM C-150.
5. RING AND COVER SHALL BE GREY CAST IRON CONFORMING TO ASTM A-48 CLASS 35B.
6. RING AND COVER STYLE AND MARKING VARY BY SPECIFYING AGENCY.
7. PRE-CAST JOINTS SHALL BE SEALED USING MASTIC.

LOCATION:T:\Drawings\Vault\DESIGN\W\HOLE\SI\H CUT SHEETS\Standard\H48_SHAFT-STD\30x36-NoStep.dwg



240 W. LOS ANGELESE AVE. SIMI VALLEY, CA 93065
P: (805) 527-0841 F: (805) 584-0769,
WWW.PRE-CONPRODUCTS.COM

THE CONTENTS OF THESE DRAWINGS ARE THE PROPERTY OF PRECON PRODUCTS AND ARE PROPRIETARY AND CONFIDENTIAL. THESE DOCUMENTS SHALL NOT BE DISSEMINATED FOR ANY OTHER USE, WITHOUT THE WRITTEN CONSENT OF PRECON PRODUCTS. IF YOU RECEIVE THESE DRAWINGS IN ERROR, RETURN TO SENDER WITHOUT READING, COPYING OR DISCLOSING THE CONTENTS.

DRAWN BY:
W. TACK
DATE:
7/7/2021

TITLE:
MANHOLE, 48" DIA, 30" RING & COVER

SHEETS:
1 OF 1
DO NOT SCALE