

PLAN VIEW

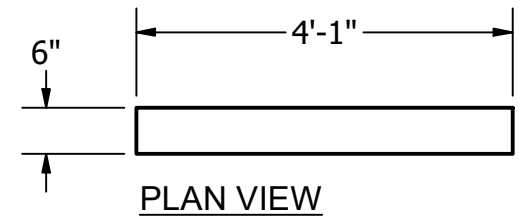

PLAN VIEW

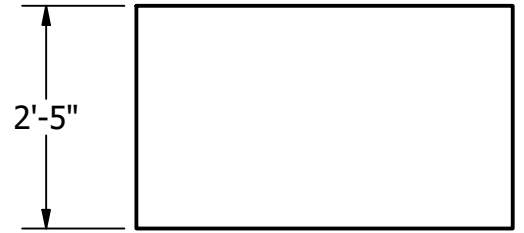

PROFILE VIEW

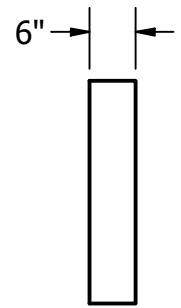

SIDE VIEW

NOTES: UNLESS OTHERWISE SPECIFIED.

1. CONCRETE SHALL HAVE A MINIMUM COMPRESSIVE STRENGTH F_C = 5000 PSI AT 28 DAYS. MIX DESIGN 1595455 SCC.
2. THE PORTLAND CEMENT USED IN THE PRECAST SECTIONS SHALL MEET THE REQUIREMENTS OF TYPE II/V HIGH SULFATE RESISTANT CEMENT IN ACCORDANCE WITH ASTM C-150.

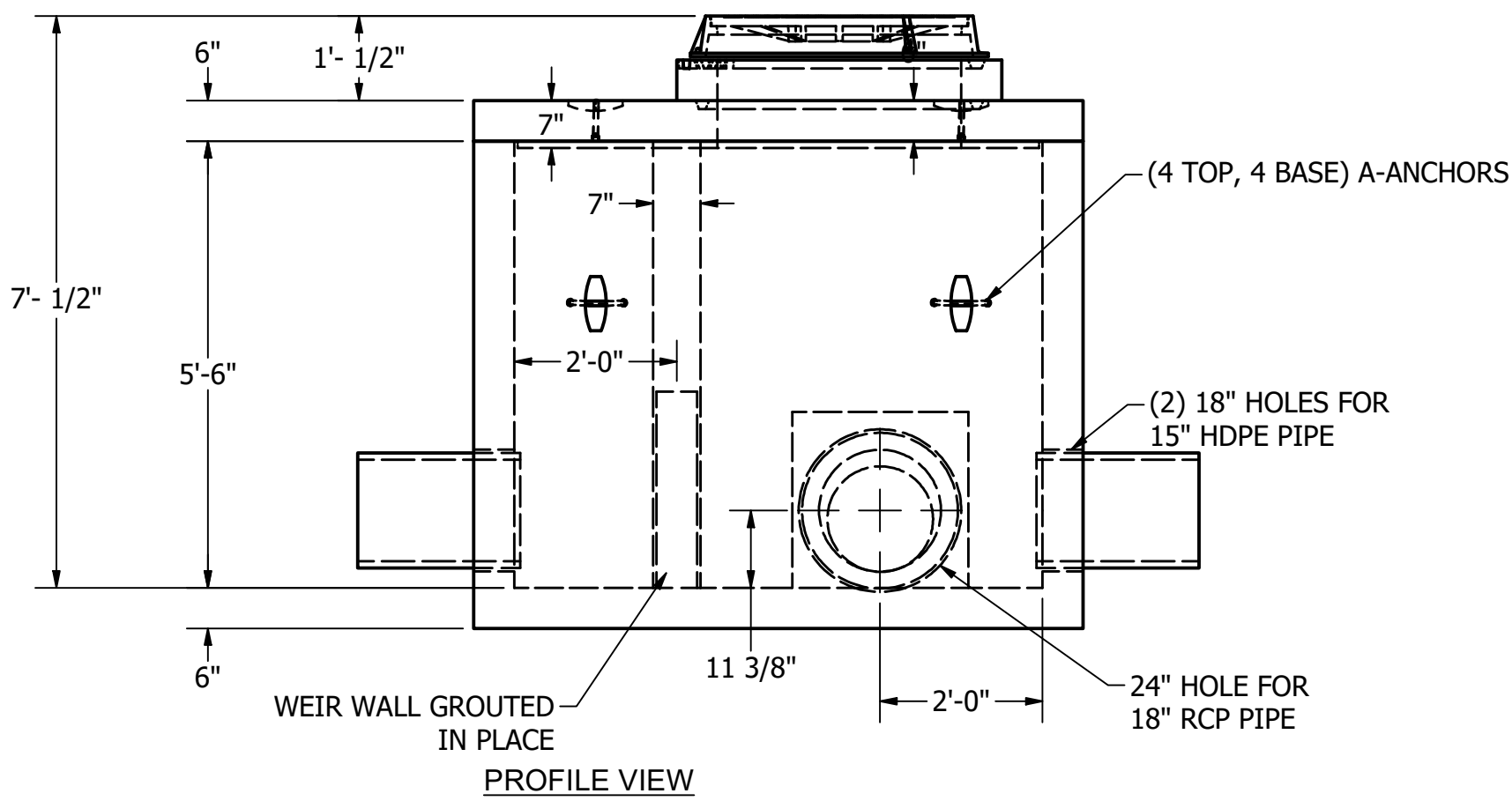

PROFILE VIEW

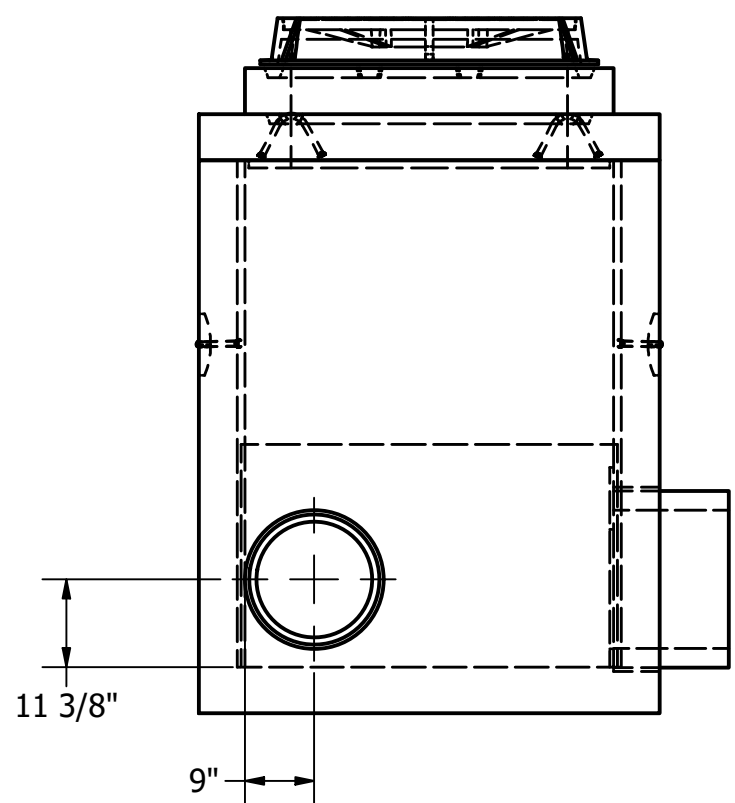

END VIEW

REVISIONS:
No. DATE DESCRIPTION

DO NOT SCALE

PRECON
240 W. LOS ANGELES AVE.
SIMI VALLEY, CA 93065
P: (805) 527-0841 F: (805) 584-0769,
WWW.PRE-CONPRODUCTS.COM

TITLE:
6'-6" x 4' DIVERSION VAULT

DRAWN BY:
K.STRADER

DATE:
3/10/2021

SHEET:
1 OF 1

LOCATION: T:\Drawings\Vault\DESIGN\Boxes\Website\6'-6" x 9' Diversion Vault\6.5x 4x 3.5 Diversion Vault.dwg