

1'x 9'x 7' HEADWALL

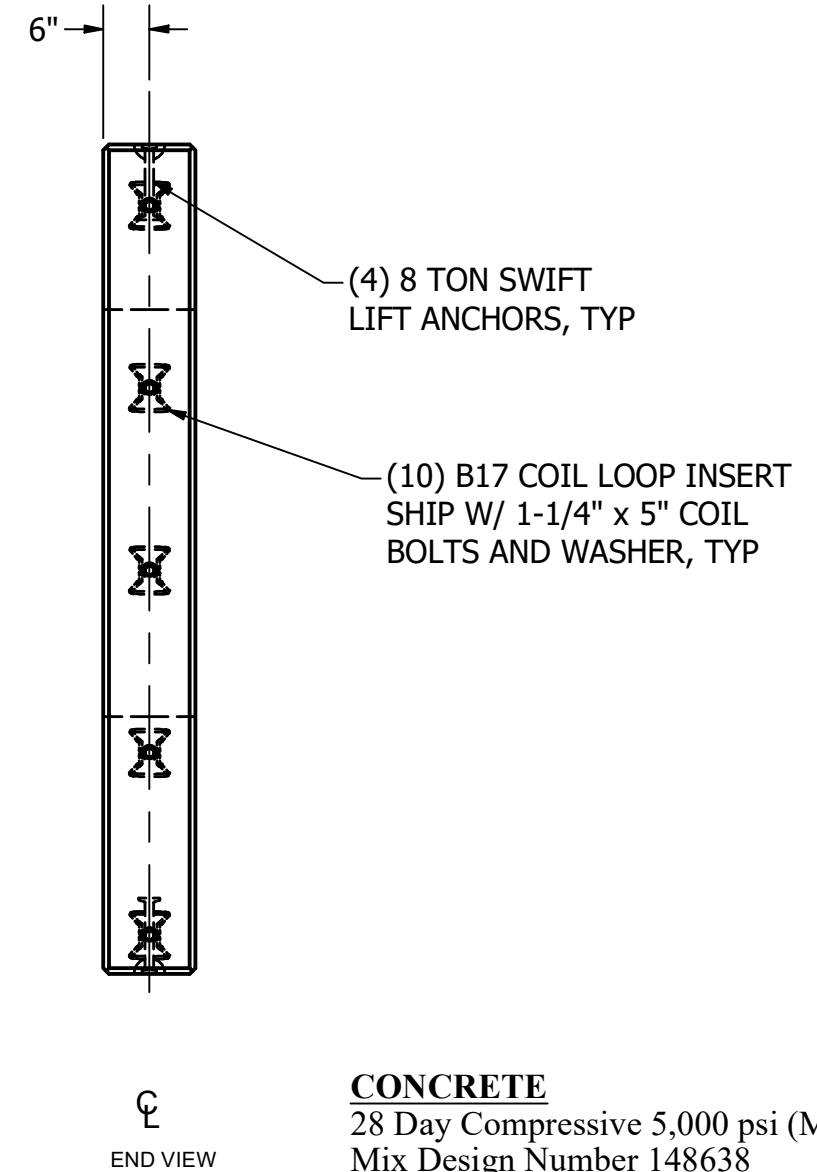
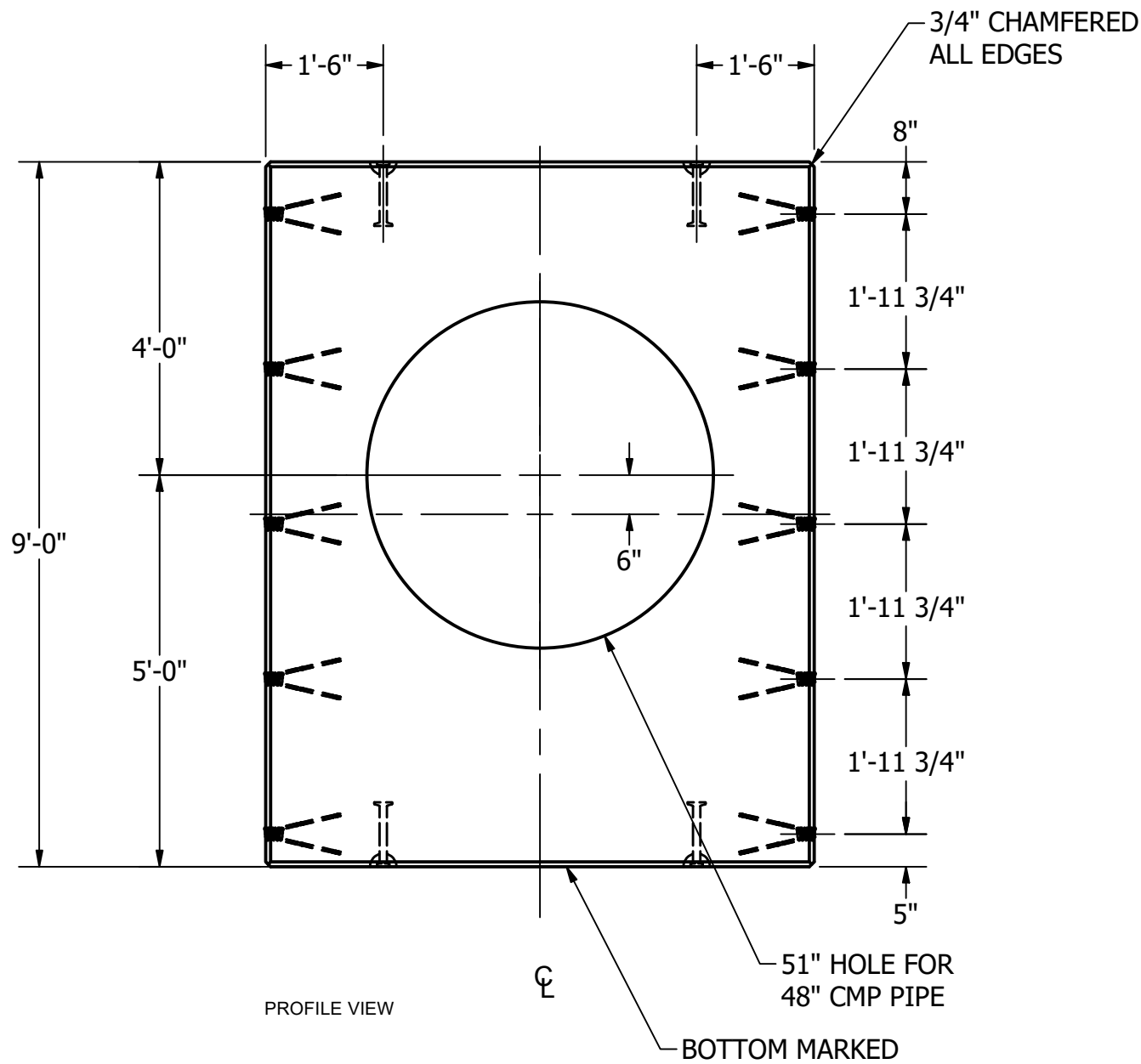
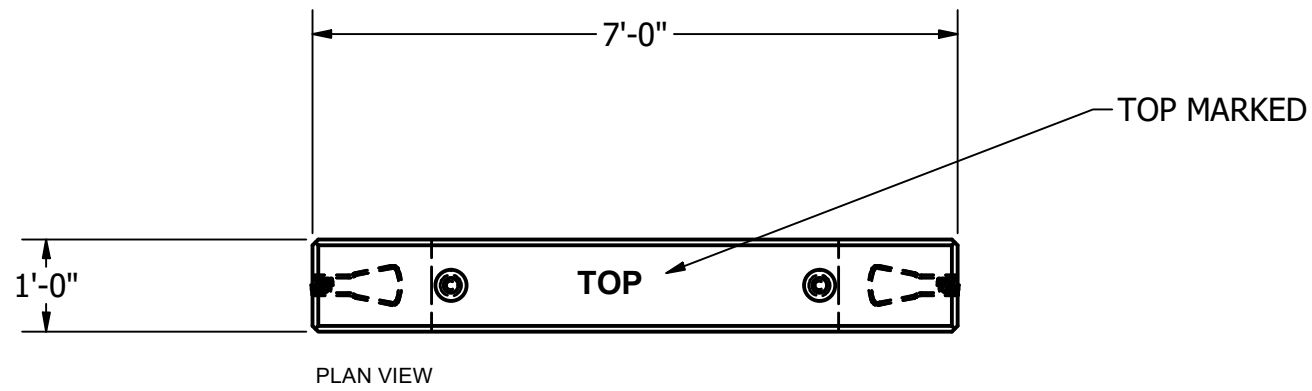

CONCRETE
 28 Day Compressive 5,000 psi (Minimum)
 Mix Design Number 148638
 Lifting Strength 2000 psi (Minimum)

REVISIONS:	No.	DATE	DESCRIPTION

THE CONTENTS OF THESE DRAWINGS ARE THE PROPERTY OF PRECON PRODUCTS AND ARE PROPRIETARY AND CONFIDENTIAL. THESE DOCUMENTS SHALL NOT BE DISSEMINATED FOR ANY OTHER USE, WITHOUT THE WRITTEN CONSENT OF PRECON PRODUCTS. IF YOU RECEIVE THESE DRAWINGS IN ERROR, RETURN TO SENDER WITHOUT READING, COPYING OR DISCLOSURING THE CONTENTS.

DO NOT SCALE

240 W. LOS ANGELES AVE.
 SIMI VALLEY, CA 93065
 P: (805) 527-0841 F: (805) 584-0769
 WWW.PRE-CONPRODUCTS.COM

TITLE: **1'x 9'x 7' PRECAST CONCRETE HEADWALL**

DRAWN BY: **K.STRADER**

DATE: **2/5/2019**

SHEET: **1 OF 1**

LOCATION: T:\Drawings\Vault\DESIGN\NS\Lagg Panels\Website\1'x9'x7' head wall sample.dwg