

FRAME AND GRATE
 STANDARD: GALVANIZED STEEL TRAFFIC RATED.
 OPTIONAL: ADA, HIGH HEEL PROFF, SOLD COVER,
 CAST IRON WARKWAY OR TRAFFIC.

WEIGHTS		
PART NUMBER	HIGHTS	APPROX. LBS
1818x6	6"	183
1818x18	17"	549
1818-B18 OPEN	18"	549
1818-B18F	22"	671

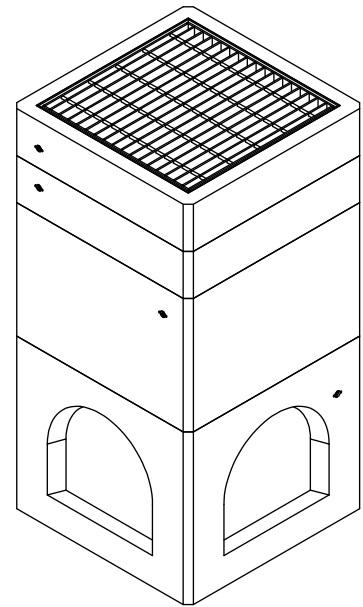

ISOMETRIC VIEW

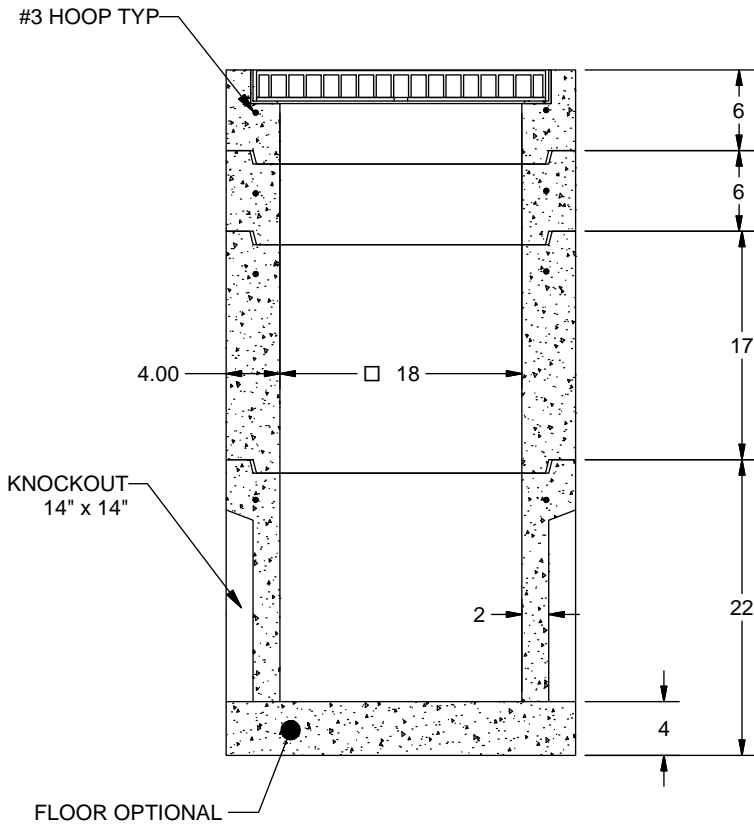

SECTION A-A

THIS CATCH BASIN IS A STACKABLE UNIT. THE SHORTEST YOU MAY GO WITH KNOCKOUTS IS 18". THE SHORTEST WITHOUT KNOCKOUTS IS 6".

1. ALL DIMENSIONS ARE IN DECIMAL INCHES.
2. PRECAST MATERIALS AND MANUFACTURING METHODS SHALL CONFORM TO ASTM C-913.
3. BOX DESIGN LOAD H-20 TRAFFIC.
4. CONCRETE SHALL HAVE A MINIMUM COMPRESSIVE STRENGTH F C= 4000 PSI AT 28 DAYS.
5. THE PORTLAND CEMENT USED IN THE PRECAST SECTIONS SHALL MEET THE REQUIREMENTS OF TYPE II/V HIGH SULFATE RESISTANT CEMENT IN ACCORDANCE WITH ASTM C-150.



TITLE			
CATCH BASIN, 18" x 18", STANDARD			
DRAWN BY	DATE	MODEL NO.	SH 1 OF 1
K. STRADER	12/14/2005	CB1818	

APPROVED BY	DATE	APPROVED BY	DATE
-------------	------	-------------	------