

**FRAME AND GRATE**  
 STANDARD: GALVANIZED STEEL TRAFFIC RATED.  
 OPTIONAL: ADA, HIGH HEEL PROOF, SOLID  
 COVER, CAST IRON PARKWAY OR TRAFFIC.

| WEIGHTS       |        |             |
|---------------|--------|-------------|
| PART NUMBER   | HIGHTS | APPROX. LBS |
| 1212x6        | 6"     | 131         |
| 1212x12       | 11"    | 241         |
| 1212-B12 OPEN | 12"    | 263         |
| 1212-B12F     | 16"    | 350         |

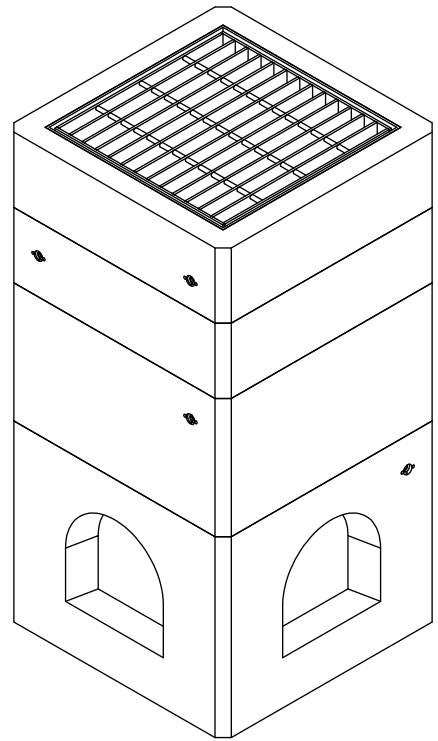

**ISOMETRIC VIEW**

THIS CATCH BASIN IS A STACKABLE UNIT. THE  
 SHORTEST YOU MAY GO WITH KNOCKOUT IS 12".  
 THE SHORTEST WITHOUT KNOCKOUTS IS 6".

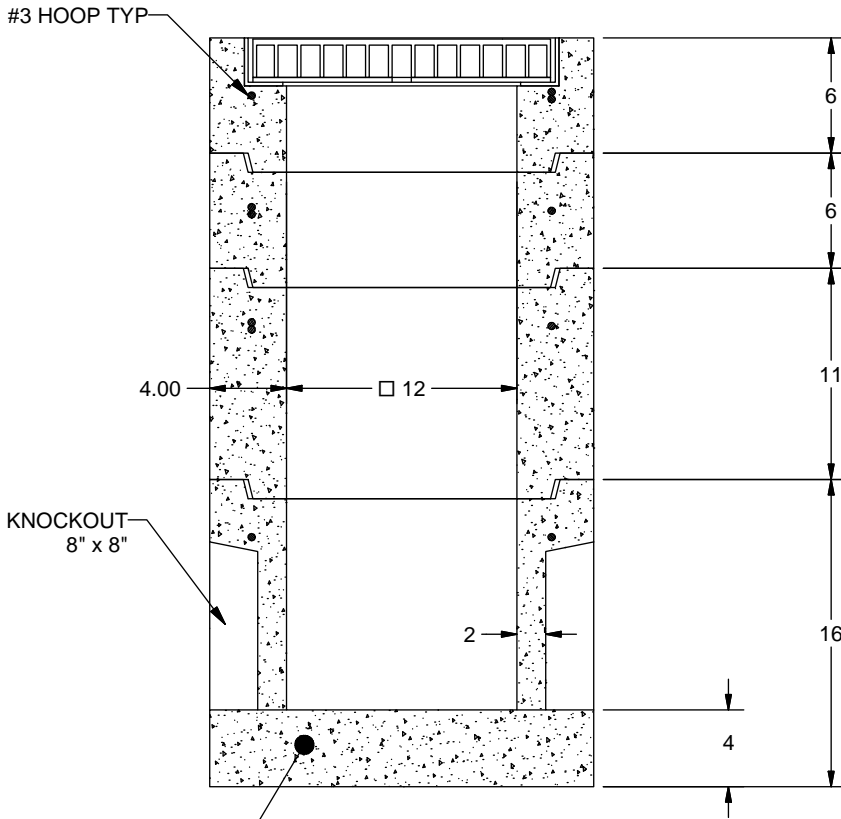

**SECTION A-A**

1. ALL DIMENSIONS ARE IN DECIMAL INCHES.
2. PRECAST MATERIALS AND MANUFACTURING METHODS SHALL CONFORM TO ASTM C-913.
3. BOX DESIGN LOAD H-20 TRAFFIC.
4. CONCRETE SHALL HAVE A MINIMUM COMPRESSIVE STRENGTH F C= 4000 PSI AT 28 DAYS.
5. THE PORTLAND CEMENT USED IN THE PRECAST SECTIONS SHALL MEET THE REQUIREMENTS OF TYPE II/V HIGH SULFATE RESISTANT CEMENT IN ACCORDANCE WITH ASTM C-150.



Phone (805) 527-0841 Fax (805) 584-0769

|                                  |          |           |           |
|----------------------------------|----------|-----------|-----------|
| TITLE                            |          |           |           |
| CATCH BASIN, 12" x 12", STANDARD |          |           |           |
| DRAWN BY                         | DATE     | MODEL NO. |           |
| K. STRADER                       | 7/9/2008 | CB1212    | SH 1 OF 1 |

|             |      |             |      |
|-------------|------|-------------|------|
| APPROVED BY | DATE | APPROVED BY | DATE |
|-------------|------|-------------|------|